

| Job Information | Print Information | Artwork Advisory |
|-----------------|-------------------|------------------|
|-----------------|-------------------|------------------|

Job No:
Description: Sample
Product: ColourCoat Durham
Colour: Pantone xxxx
Proof No: 1
Date:
Repro: AE

Process: Screen
Dimensions: 170 x 70mm
Colour(s): 5
 Pantone xxxx
 Pantone xxxx
 Pantone xxxx
 Pantone xxxx
 Pantone xxxx

All dimensions are +/- manufacturing tolerances
 *Faces indicate a right hand drinker,
 Screen printed detail must be at least 1pt (0.353mm) thick
 Text should be minimum 8pt to remain legible.
 Light text on a dark background will reproduce better if bold

Where spot colour references are not supplied we will apply a Pantone for you

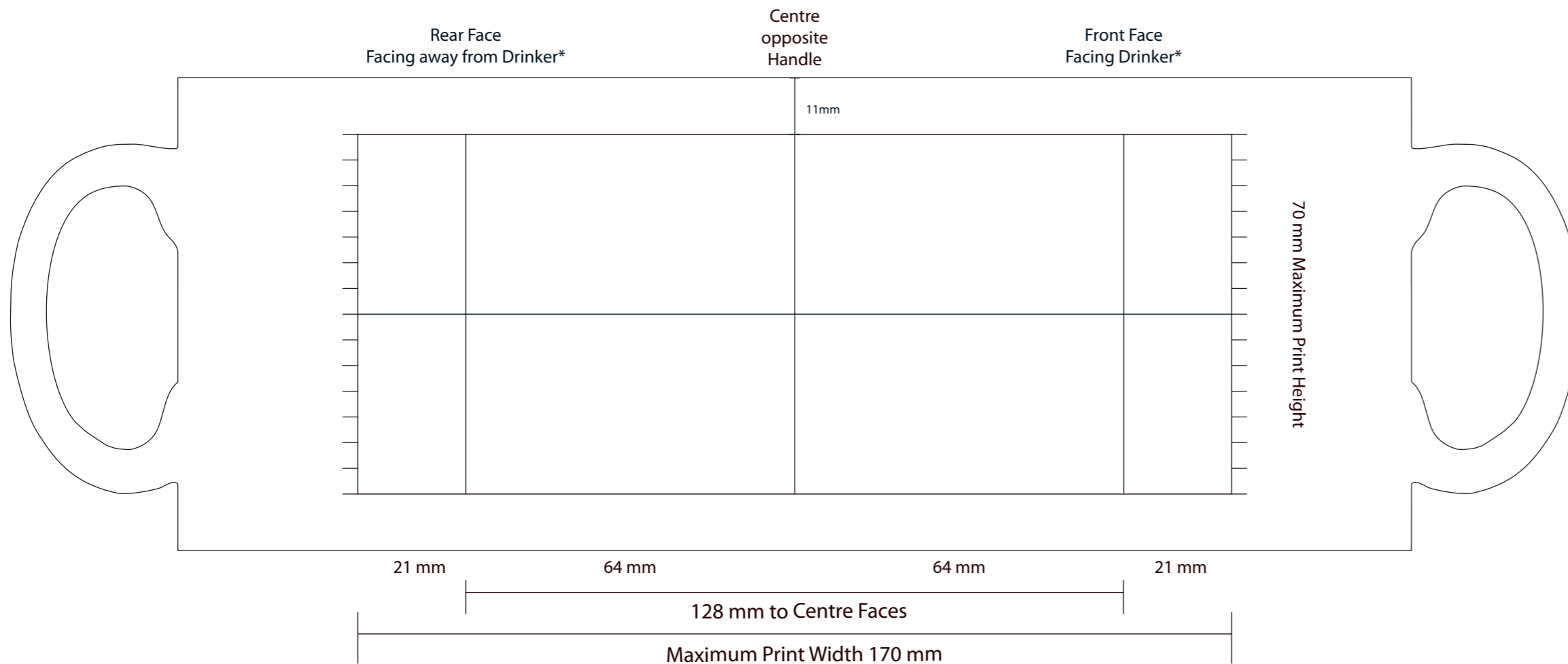
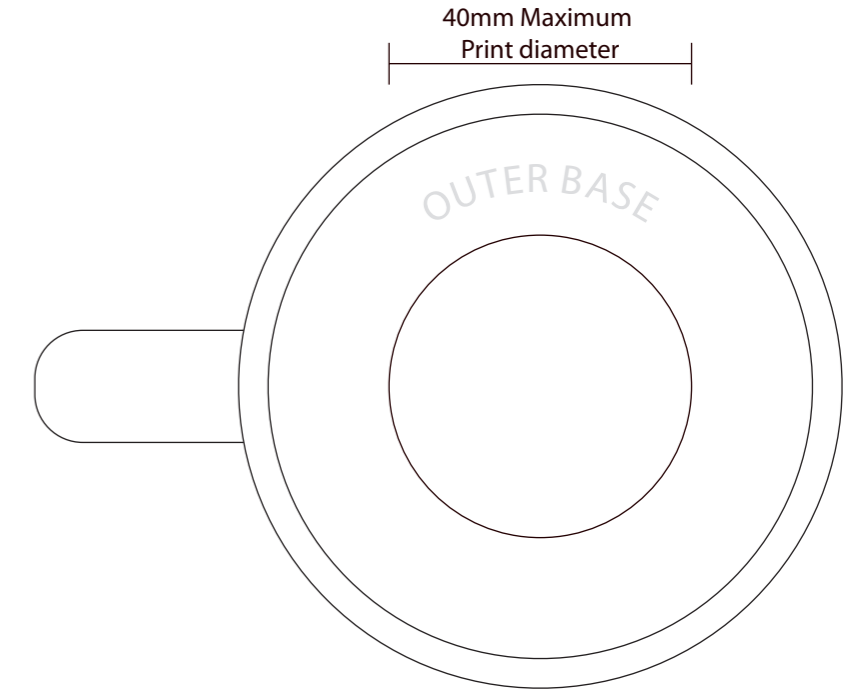

Due to variations beyond our control and the nature of the print process the colour on the pdf may differ from that on the final product.