

YOUR VISUAL PROOF (1 of 2)

Order Reference xxxxxx
Date created xx/xx/xx
Created by xx

Product 234223
Colour XXXc (colour in swatches)
Branding Spot Colour

PANTONE® Colours



Artwork Advisories

This template is to be used as a guide for print size & positioning only.

Please note that the 2 strips are a continuous loop and have no break at the right ends.

It is the customer's responsibility to ensure that the proof is correct in all areas. Please be sure to double-check spelling, grammar, layout and design before approving artwork. Due to the variation in monitor colours and adjustments, PDF proofs may not provide an accurate representation of the final product & printed work. Once artwork is approved, your order will be processed based on the above unless any amendments are made. All orders are subject to our terms and conditions.

Please email all approvals/amends to your order processor.

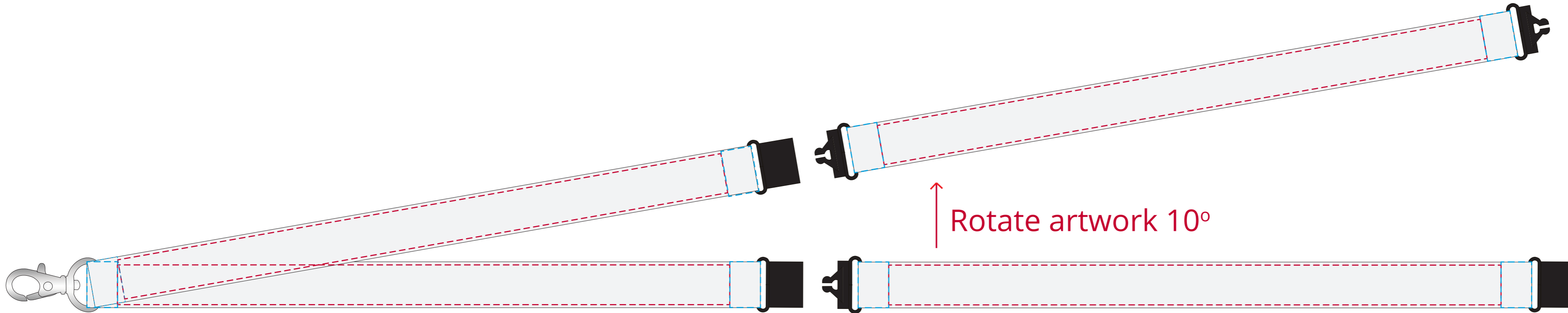

- - - - - Print area
- - - - - Keep all logos 10mm away from the clip/break, to avoid stitching

Visual purposes only. Please see page 2 for actual artwork size.

YOUR VISUAL PROOF (2 of 2)

Order Reference	xxxxxx
Date created	xx/xx/xx
Created by	xx

Print area	13 x 820 mm
Logo size	xx x xxmm
Branding	Spot Colour

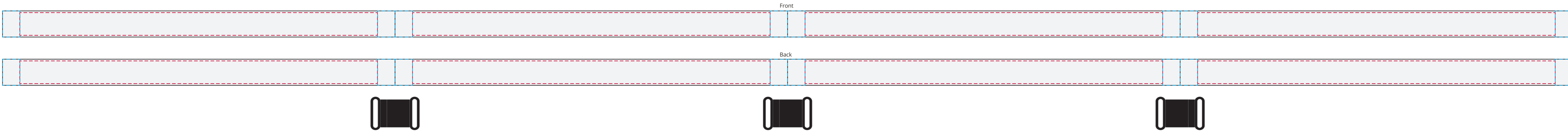

- - - - - Print area
- - - - - Keep all logos 10mm away from the clip/break, to avoid stitching

Visual scale 100%.